



#### TECHNICAL DATA



GENERAL		TW25KX	TW25VL
Load capacity to 500 mm	kg	2500	2500
Load capacity to 600 mm	kg	2320	2320
Unladen weight	kg	3728*	3722*
Transmission	-	Hydrostatic	Hydrostatic
Joystick	-	Yes	Yes
MAST			
Fork carriage	-	FEM 2	FEM 2
Carriage width	mm	1100	1100
Lifting/lowering speed (loaded)	m/s	0.16 / 0.45	
ENGINE			
Brand	-	KUBOTA	KOHLER
Model	-	V1505	KDI1903
Power	kW	18.5	36.5
Rpm	rpm	2300	2600
Torque	N·m@rpm	92.5@1600	170@1700
No. cylinders	-	4	3
Emissions	-	Stage V	Stage V
Alternator	V - A	12 - 40	12 - 100
DRIVING			
Max. speed	km/h	21	24
Gradeability	%	35	25
Traction	-	4x4 disconnectable	4x4
Front tyres	-	11.5/80-15.3	11.5/80-15.3
Rear tyres	-	10.0/75-15.3	10.0/75-15.3
HYDRAULIC SYSTEM			
Hydraulic circuit	-	Single gear pump + priority valve	Single gear pump + priority valve
Flow rate	l/min	25	40
Working pressure	bar	160-180	160-180
TANKS CAPACITY			
Fuel	l	55	55
Hydraulic	l	55	55
BRAKES			
Service	-	Multi-disc on front wheels	Multi-disc on front wheels
Parking	-	Automatic multi-disc on front wheels	Automatic multi-disc on front wheels

**DIMENSIONS**

TYPE OF MAST	Maximum lift (mm)	Retracted mast height (mm)	Free lift (mm)	Load at maximum height (kg)
Duplex	3140	2290	-	2500
Duplex	3600	2520	-	2340
Triplex (Std.)	4000	2070	1330	2260
Triplex	6000	2840	2110	1040

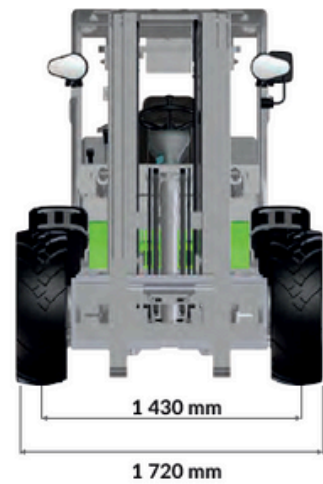
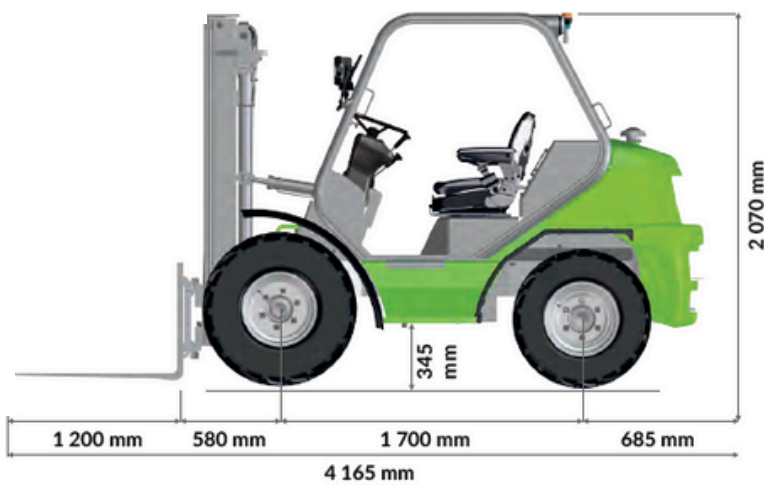

DIMENSIONS		TW25KX	TW25VL
External turning radius	mm	3725	3725
Internal turning radius	mm	2225	2225
Mast tilt forward	°	7	7
Mast tilt backward	°	10	10
Fork width	mm	100	100



[www.agrimac.es](http://www.agrimac.es)



The data contained in this document is for information purposes only. They do not represent a commitment on the part of the manufacturer and are subject to change.